

HOCHIKI
SC-PA
 Fireman Telephone Handset

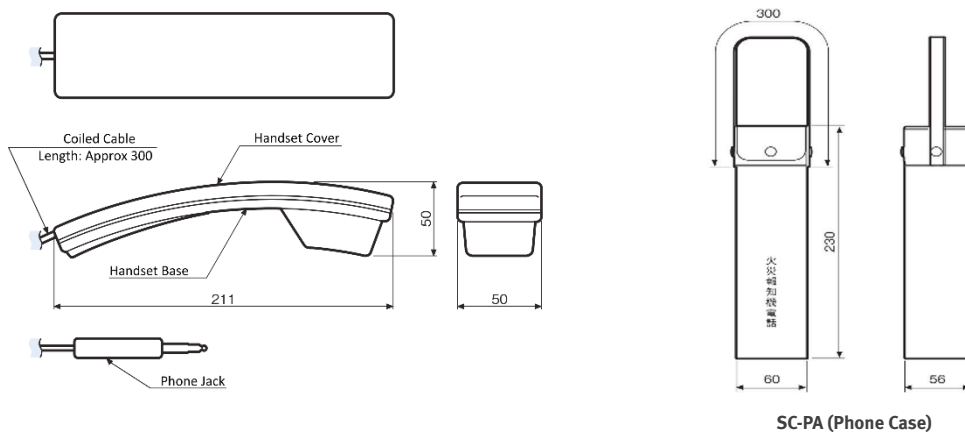

Dimension (mm)



SC-PA (Phone Case)

Specification

Type	Fireman Telephone
Model	SC-PA
Microphone Cord Plug	PJ-068
Material	Thermoplastic Resin
Color	White Ivory
Weight	Approx. 170g
Country of Origin	Japan
Accessory	SC-PA (Phone Case)*Sold Separate

*Compatible to use with Fire Alarm Control Panel, model RPP, RPQ, RPV, RPR, HRK, HRN.

HOCHIKI ASIA PACIFIC PTE. LTD.
 82 UBI Ave 4 #06-02
 Edward Boustead Centre, Singapore 408832
 TEL: 65-6841-9728 | FAX: 65-6841-9781
 URL : www.hochikiasiapacific.com

04/2020

HEAD OFFICE
 10-43 Kamiosaki 2-Chome.
 Shinagawa-Ku, Tokyo 141-8660 Japan
 TEL: 81-(3)-3444-4116 | FAX: 81-(3)-3444-4167
 URL :www.hochiki.co.jp

Specifications subject to change without notice