

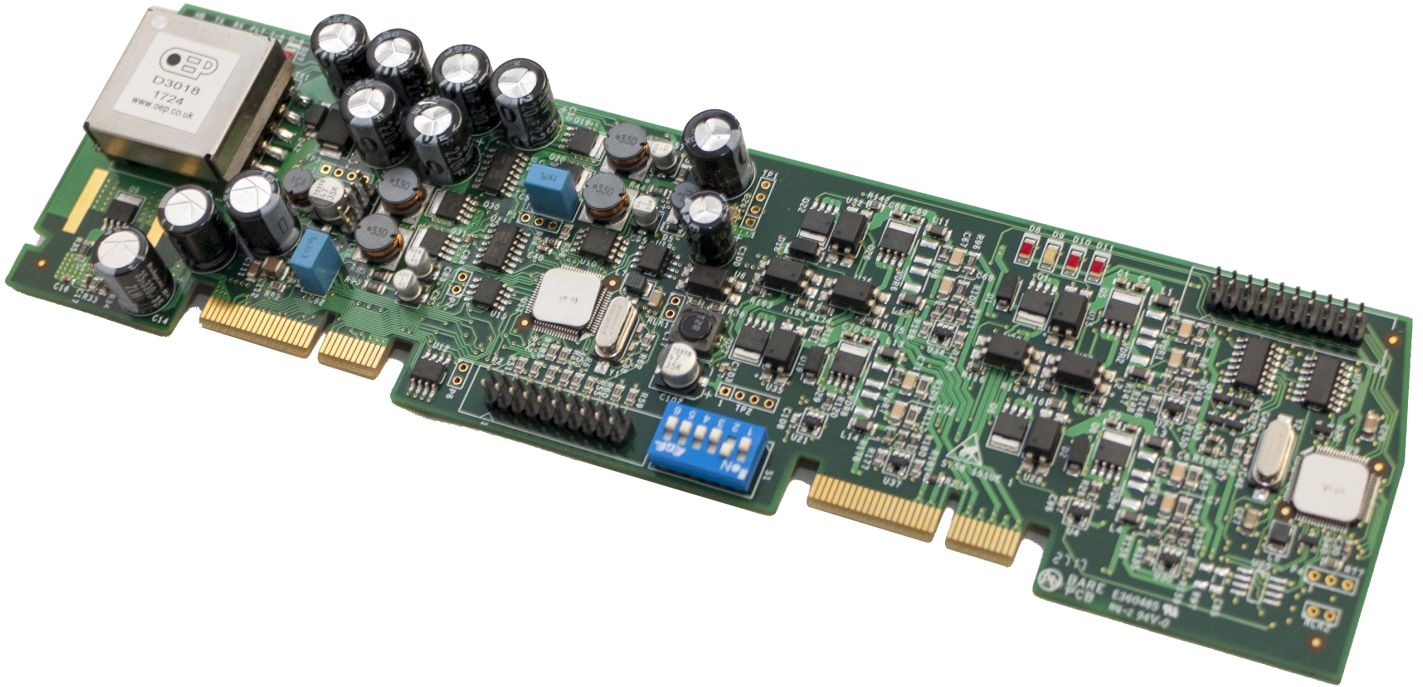

Dual Loop Panel Module (S758) Information Guide



CONTENTS

Contents	2
Compliance	3
Underwriters Laboratories (UL)	3
FCC	3
Installation	3
Introduction	4
Technical Support	4
Return Material Authorization (RMA)	4
Warranty Service	5
Advanced Replacements	5
Overview	6
Installation	7
Before You Begin	8
Setting the Address	9
Placement	10
Wiring	12
No SLC Devices	12
Class A SLC Loops	13
Class B SLC Loops	14
Class X SLC Loops	15
Testing	16
Specifications	17
Index	18

COMPLIANCE

Underwriters Laboratories (UL)

Fire Alarm Subassembly
Hochiki America Corporation

FCC

This equipment has been tested and found to comply with the limits for a Class A digital device, pursuant to Part 15 of the FCC Rules. These limits are designed to provide reasonable protection against harmful interference when the equipment is operated in a commercial environment. This equipment generates, uses, and can radiate radio frequency energy and, if not installed and used in accordance with the Installation Manual, may cause harmful interference to radio communications. Operation of this equipment in a residential area is likely to cause harmful interference in which case the user will be required to correct the interference at his own expense. Any changes or modifications not expressly approved by Hochiki America Corporation could void the user's authority to operate this equipment under the rules and regulations of the FCC.

Operation is subject to the following two conditions:

- (1) This device may not cause harmful interference, and
- (2) This device must accept any interference received, including interference that may cause undesired operation.

Installation

Install this product in accordance with NFPA 13, NFPA 72, NFPA 70, and NEC 70 and all local codes.

All field wiring should be installed using fire rated cables according to the NFPA 72. Riser conductors shall be installed in accordance with the survivability from attack by fire requirements in National Fire Alarm Code, NFPA 72, Section 12.3. Riser conductors shall employ either a 2 hour rated cable system, or meet requirements approved by the AHJ.

INTRODUCTION

Technical Support

For technical support, contact Hochiki America at 800.845.6692 or technicalsupport@hochiki.com. Hochiki technical support is available Monday through Friday, 7:00AM to 5:00PM, PST.

Prior to contacting technical support, have the following information available:

- Product part number
- Purchase order or order number
- Product serial number
- Current function of the product
- Expected function of the product
- Installation of the product

Return Material Authorization (RMA)

Contact Technical Support to obtain an RMA for any product to be returned. Returns will not be accepted without an accompanying RMA number. An RMA number is assigned when:

- Tech Support acknowledges a possible product failure.
- A product was damaged during shipping
- An incorrect product was shipped
- An order was placed using an incorrect part number *
- An order was placed using an incorrect part quantity *
- An order is no longer required *

* Restocking fees may apply.

All returned products are tested to confirm operating failures experienced in the field. If the product is found to be functional, contractors must absorb expenses for return shipping, as well as the cost and shipping of the advanced replacement product.

Prominently display the RMA number on all packages sent for return. Ship all return products to:

Attention: RMA # _____
Hochiki America

7051 Village Park Drive, Suite 100
Buena Park, CA 90621

Warranty Service

Technical Support can replace or repair a defective product when the original purchase is within the warranty period defined in the sales contract. Check your contract for more information, or contact your sales representative about your specific warranty period.

Advanced Replacements

Products that fail to operate in the field can be replaced quickly using the advanced replacement process. The advanced replacement process is available to all contractors who maintain an acceptable line of credit.

Initiate the advanced replacement process by requesting an RMA number from a Tech Support representative. Advanced replacements can be shipped to your location when the product is covered under warranty and when a replacement product is in stock.

- Advanced replacements can be expedited at the request of the contractor. Shipping costs associated with this process are the responsibility of the contractor.
- Products returned using the advanced replacement process must be received within 30 days of the RMA issue date.

OVERVIEW

The Dual Loop Panel Module provides two supervised loop functions for the fire alarm control panel. All models of the FireNET L@titude Fire Alarm Control Panel contain at least one Dual Loop Panel Module.

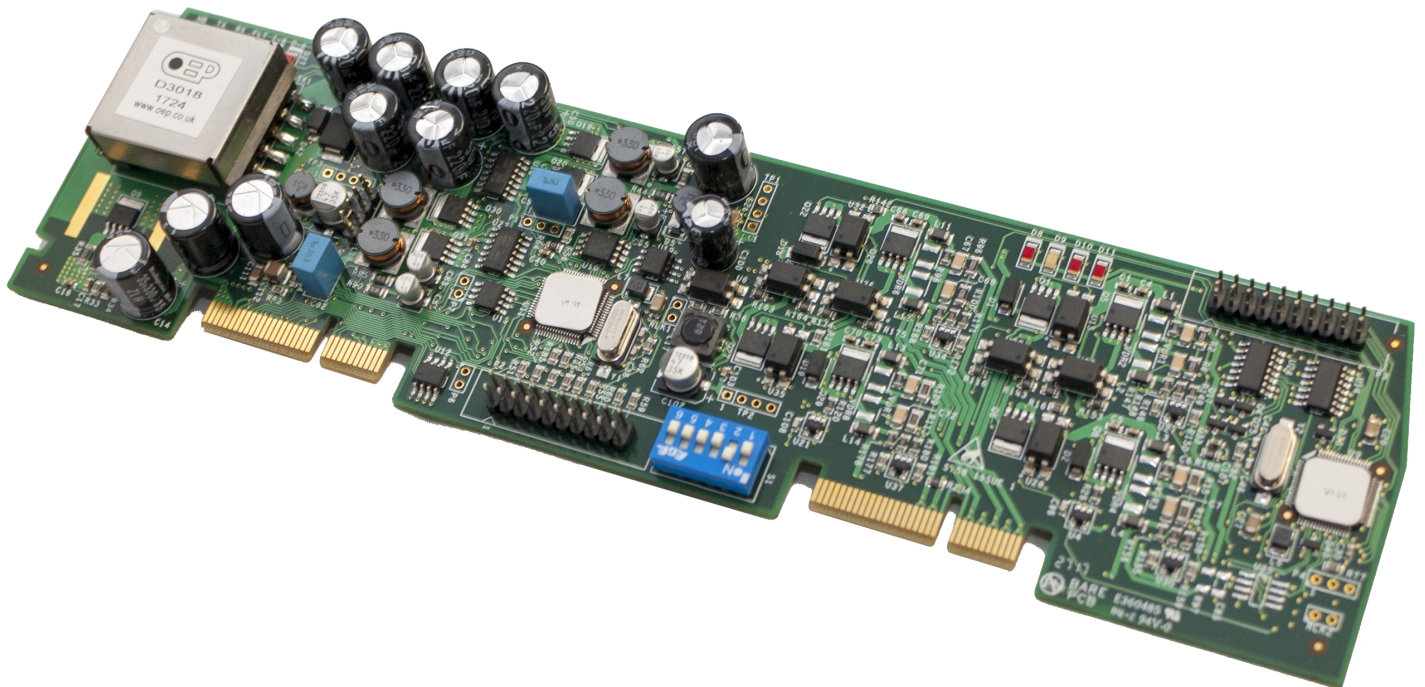

Dual Loop Panel Module

S758

The Dual Loop Panel Module monitors loop device status and provides status to the panel processor. It holds device configurations and operates in a standalone manner when catastrophic failures occur. The Dual Loop Panel Modules can be connected in any available slot (C-K) on the Main Back Board to provide this operating function.

Each Dual Loop Panel Module can support either Hochiki or Apollo protocols.

INSTALLATION

This section provides instructions for connecting cables, mounting, and testing the Dual Loop Panel Module Panel Module for installation.

<input type="checkbox"/>	Notify the monitoring center and location security that the FireNET L@titude Fire Alarm Control Panel will be temporarily out of service.
<input type="checkbox"/>	Remove the module from its packaging and check its contents.
<input type="checkbox"/>	Set the address of the module(s), as shown in Setting the Address .
<input type="checkbox"/>	Connect field wiring. Refer to Wiring below for details.
<input type="checkbox"/>	Remove AC and battery power from the panel.
<input type="checkbox"/>	Install the module(s) into an open slot on the Main Back Board and/or Extension Board.
<input type="checkbox"/>	Restore AC and battery power.
<input type="checkbox"/>	Wait for the panel start-up process to complete. Refer to the FireNET L@titude Fire Alarm Control Panel Installation Manual (MAN-1431HA) for more information.
<input type="checkbox"/>	Test communication from the panel via the LED Status Indicators .

Install this product in accordance with NFPA 72, the National Electrical Code, and all local codes.

WARNING! The module must be installed by personnel familiar with electronic components. Electronic components within the module are vulnerable to damage from electrostatic discharge. Ground straps must be worn by installers before handling to prevent electrostatic discharge damage.

Before You Begin

The following item is not included with the FireNET Latitude Fire Alarm Control Panel, but is required for the installation:

- A Ground Strap is required for handling circuit boards.

Setting the Address

There can be up to 4 Dual Loop Panel Modules connected to a FireNET L@titude Fire Alarm Control Panel. Configure an address on the Dual Loop Panel Module by selecting a binary number on the SW1 DIP switch. Address 32 must be set to off on all DIP switches.

Each panel module of the FireNET L@titude Fire Alarm Control Panel must contain a unique setting before being connected to the Main Back Board. The binary setting of the DIP switch sets the specific address for the panel module. The numeric order of the address setting between modules does not impact operation, but each panel module must be assigned a separate / unique address.

The black portion of the DIP switch identifies the switch actuator.



Address 0 is shown above for illustrative purposes only. Address 0 should never be used.

For addresses above 15, switches 5 and 6 will need to be used.

- For address 16-31, switch 5 should be in the ON position. Switch 5 ALONE adds 16 to the address number. For example, for address 20, set the switch position to address 4 shown above and switch 5 in the ON position.
- For address 32-47, switch 6 should be in the ON position. Switch 6 ALONE adds 32 to the address number.
- For address 48-63, switches 5 AND 6 should be in the ON position. Switches 5 and 6 TOGETHER adds 48 to the address number.

Placement

To install modules on the FireNET L@titude Fire Alarm Control Panel:

1. Disconnect AC power and standby batteries prior to performing the module installation.
2. Remove the retaining screw and plastic cover.



3. Remove the panel module from the protective packaging using adequate electrostatic protection.
4. Point the conductor side of the panel module toward the backplate.
5. Insert the notched end of the panel module in the metal guide notch of the backplate at an angle, as shown.

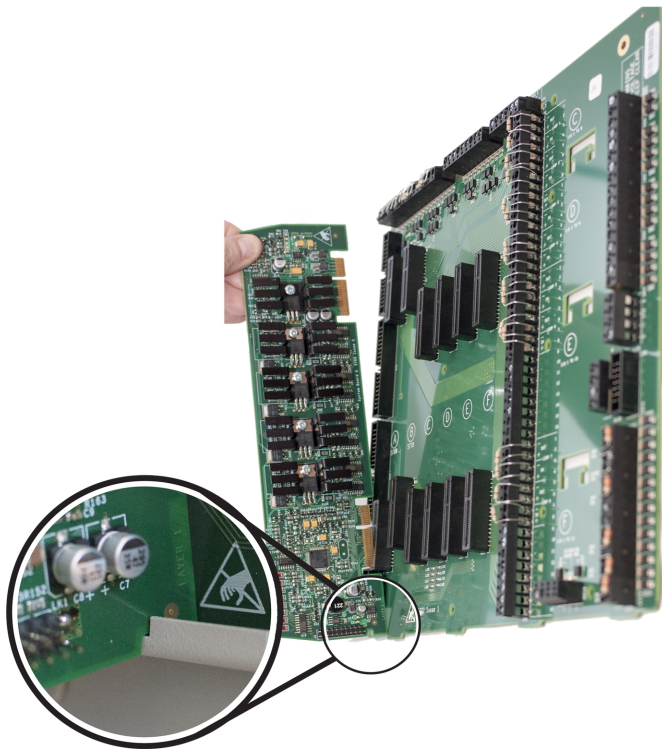

The photo above is an example of panel module placement and may not be representative of the specific module and slot placement described in this guide. Refer to the checklist above for details on placement.

6. Rotate the panel module until all conductors are securely inserted into connectors of the Main Back Board.
7. Replace the cover onto the Main Back Board.
8. Reconnect the batteries and restore AC power.

Wiring

No SLC Devices

When the loop is unused, the loop termination jumpers provided with the panel should be replaced with 14-22 AWG SLC cable.

The FireNET L@titude Fire Alarm Control Panel provides a trouble signal when unused loops are not terminated. All loops are supervised.

DUAL LOOP MODULE WIRING WITH NO DEVICES CONNECTED

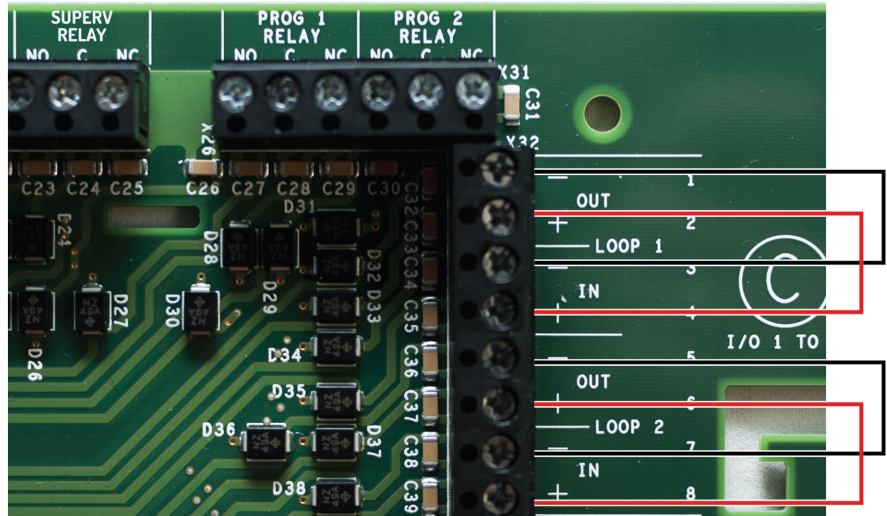

Class A SLC Loops

1. Connect Class A loops to the terminal strip of the FireNET L@titude Fire Alarm Control Panel.
2. When the loop is unused, the loop termination jumpers provided with the panel should be replaced with 14-22 AWG SLC cable.

The FireNET L@titude Fire Alarm Control Panel provides a trouble signal when unused loops are not terminated. All loops are supervised.

Follow NFPA guidelines for placement of isolators with Class A wiring.

CLASS A LOOP CONNECTION CONTAINING SIX ADDRESSABLE SENSORS

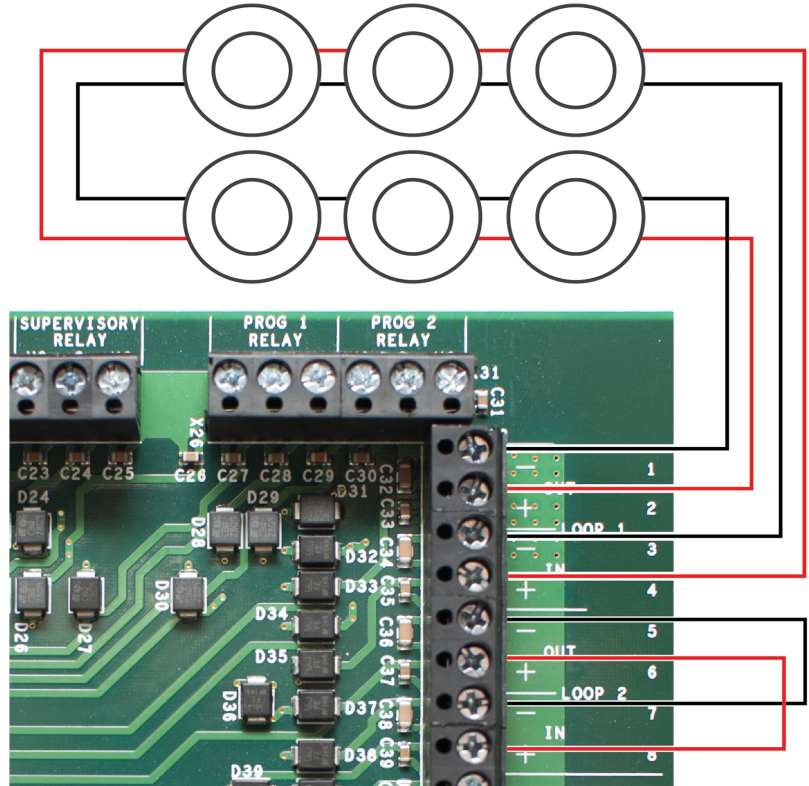

Class B SLC Loops

Class B loops may not be permitted in all regions. Check local codes of practice before using Class B SLC circuit configurations.

1. Connect Class B loops to both the IN and OUT terminals of the terminal strip. Do not insert more than one conductor per terminal. Use wire nuts or other suitable splice connectors to connect the Class B loop cable to both the IN and OUT terminals.
2. When the loop is unused, the loop termination jumpers provided with the panel should be replaced with 14-22 AWG SLC cable.

CLASS B LOOP CONNECTION
CONTAINING THREE ADDRESSABLE SENSORS

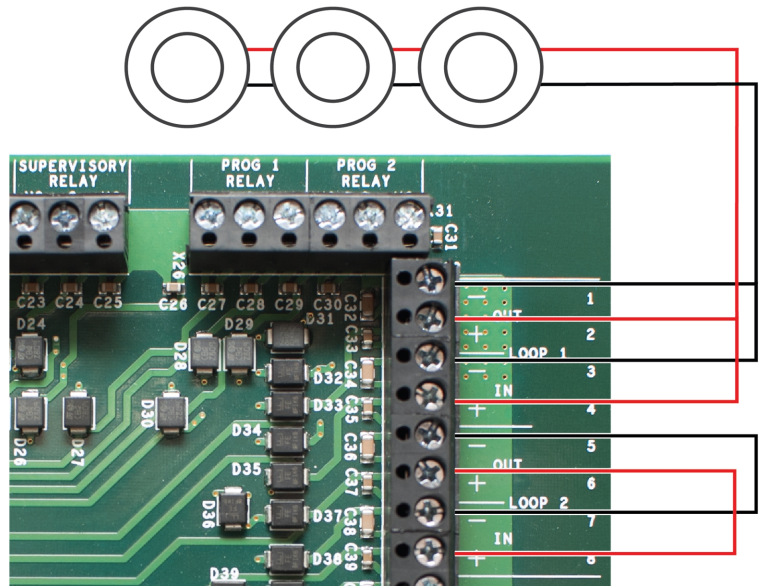

SLC cabling must be sized according to length and device load to ensure that the voltage-drop of the cable does not result in an inadequate operating voltage on the circuit.

Refer to the FireNET L@titude Fire Alarm Control Panel Installation Manual (MAN-1431HA) for an example of how isolators may be used on a Class B circuit.

Class X SLC Loops

1. Connect Class X loops to the terminal strip of the FireNET L@titude Fire Alarm Control Panel.
2. When the loop is unused, the loop termination jumpers provided with the panel should be replaced with 14-22 AWG SLC cable.

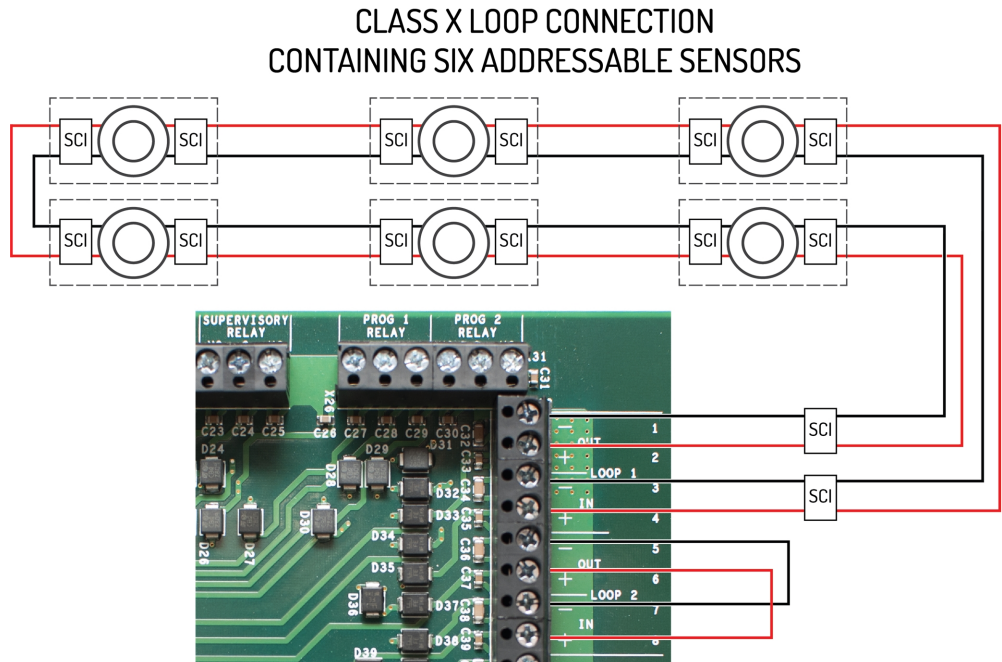

The FireNET L@titude Fire Alarm Control Panel provides a trouble signal when unused loops are not terminated. All loops are supervised. Follow NFPA guidelines for placement of isolators with Class X wiring.

When using Class X wiring, SCI Short Circuit Isolators must be installed before and after each analog addressable device on the SLC loop. Alternatively, analog devices with built-in SCI may be used.

The wiring from the control panel to the first SCI and from the last SCI back to the control panel must be in conduit.

Testing

LED indicators provide diagnostic information to identify communication.

LED Label	Name	Color	Description
LED D8	Heartbeat	Red	Heartbeat for Processor 2
LED D9	Trouble	Yellow	Trouble status for Processor 2
LED D10	Loop 1	Red	Identifies whether Loop 1 is on or off.
LED D11	Loop 2	Red	Identifies whether Loop 2 is on or off.
HB	Heartbeat	Red	Identifies functional status of Dual Loop Panel Module.
TX	Tx Comms	Green	Identifies transmitting data.
RX	Rx Comms	Green	Identifies receiving data.
FLT	Trouble	Yellow	Identifies an error condition.
I-A	Input Active	Red	Indicates that the input is actively receiving data.
O-A	Output Active	Red	Indicates that the output is actively transmitting data.

SPECIFICATIONS

This appendix provides electrical and environmental specifications for the Dual Loop Panel Module.

Supply Voltage	24 V DC
Loop Voltage Range	25 - 38 V DC
Maximum Loop Current	400 mA
Maximum Current Consumption	1.5 A
Protocol(s) Supported	Hochiki
Temperature Range	-5°C - 49°C or 23°F - 120°F
Relative Humidity	Up to 95%, non-condensing
Dimensions	234.6mm x 62.8mm or 9¼" x 2½"

INDEX

C

Cabling 14
Class A 3, 13
Class B 14
Class X 15

D

DIP Switch 9
Dual Loop 6-7, 17

H

Heartbeat 16

M

Main Back Board 6-7

S

SLC 12
Standby Batteries 10

T

Terminals 14
Trouble 12