

PATHWAY PRO 5G



STANDARD FEATURES

- Meets UL 864 requirements for sole primary communications
- Includes M2M communicator, RS232 connector cable, antenna and enclosure
- Remote firmware updates
- Monitor event transmission data & manage device inventory from the CLSS web portal
- Exceptional Redundancy - Dual-SIM device picks the strongest signal from AT&T or Verizon. If one network becomes unavailable, the communicator connects to the other network
- Built-in trouble relay provides local indication of communicator trouble or loss of power (connects to an FRCM module, which is not included)

APPLICATION

The Hochiki Pathway Pro 5G Communicator provides a Supervising Station communication platform for use with the FireNET Plus fire alarm control panel.

The Communicator connects to the PC port of the FireNET Plus control panel offering full event reporting by address, combined with the powerful capabilities of the CLSS Cloud. The Dual-Path Communicator provides data transmission by utilizing LTE CAT-M1 networks serving as a bridge between the FireNET Plus and the CLSS Cloud.

Connection and mounting are simplified using the enclosure kit, and integration of the panel and communicator is quickly accomplished using Hochiki's Loop Explorer 2 software. Installers can select the central station service they wish to use from a list of approved central station providers found in the CLSS web portal.

HOCHIKI SPECIFICATIONS

Electrical

Supply Voltage	+12 to +29 VDC
Power Consumption	<ul style="list-style-type: none"> • Standby: 60 mA • Peak: 200 mA
Frequency	LTE CAT-M1 700/850/1700/1900/2100 MHz

Environment

Operating Temperature	32°F to 120°F (-10° C to 50° C)
Relative humidity:	1% to 85% Non-condensing

Physical

Dimensions	8.0" L x 7.48" W x 1.75" D
Weight (without antenna)	2.56 oz 72.57 gm
RoHS	Yes

Network Providers

- AT&T, North America
- Verizon, North America
- Other provider in the area networks

Standards and codes

The Pathway Pro 5G is UL 864 Compliant - Control Units and Accessories for Fire Alarm Systems Units

Approvals

ETL Listed FCC

Specifications subject to change without notice.

PATHWAY PRO 5G

System Diagram

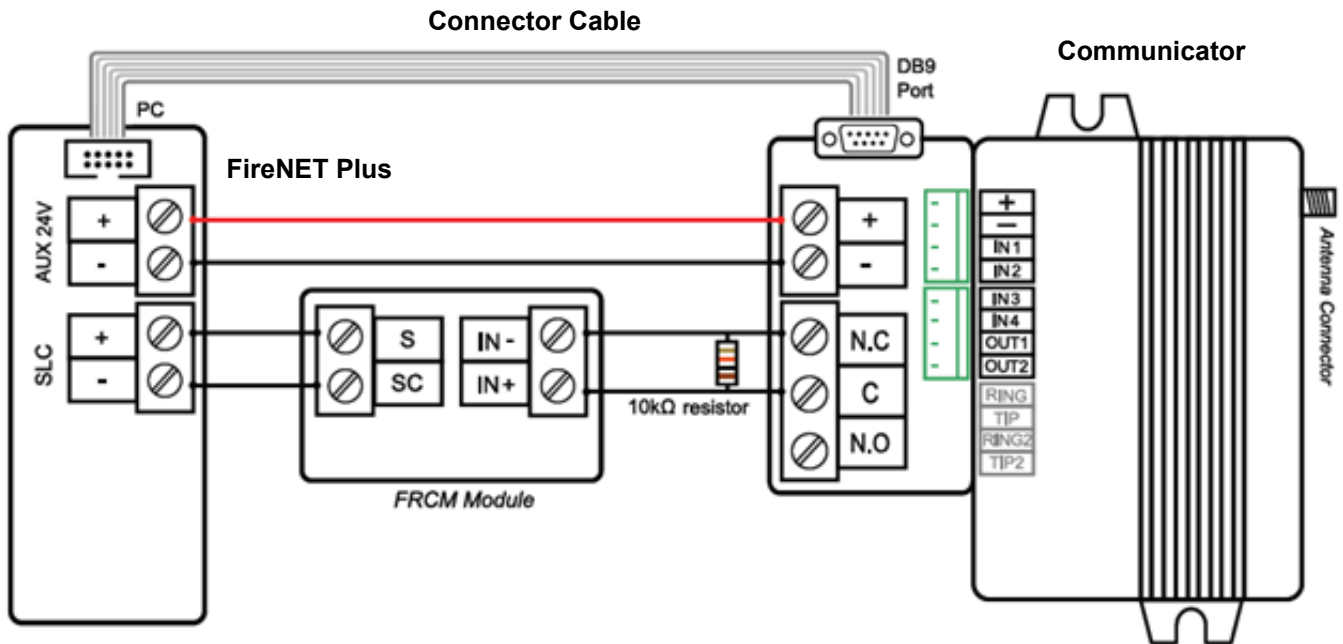

Commonly Asked Questions

- Can I use one Pathway Pro 5G to report all events from a network of FireNET Plus panels?
Yes. The Pathway Pro 5G can connect to any of the FireNET Plus panels and report all events from all panels.
- Do I need to update the firmware in my FireNET Plus panel to use the Pathway Pro 5G?
Yes. The firmware will need to be updated to use the new Pathway Pro 5G. Contact Hochiki to get the firmware file.
- How do I program the FireNET Plus panel to work with the Pathway Pro 5G?
The panel programming is very similar to how the internal DACT is programmed.
- Is any additional programming required to activate the Pathway Pro 5G?
Yes. The Pathway Pro 5G must be enrolled on the CLSS Platform. A QR code is provided with each unit. Scan the code to enroll and configure each Pathway Pro 5G communicator.
- Will the Pathway Pro 5G report to my central station?
Yes. The Pathway Pro 5G will report events to the CLSS Platform. From there, signals will be transmitted to your central station. The assignment of central station is part of the CLSS enrollment process.
- Will the Pathway Pro 5G work with my older FireNET panels?
No. The Pathway Pro 5G is only compatible with FireNET Plus.

For additional information please contact Hochiki America Corporation.