

**HOCHIKI**

## EMB-6

Fire alarm bell



### Dimension (mm)

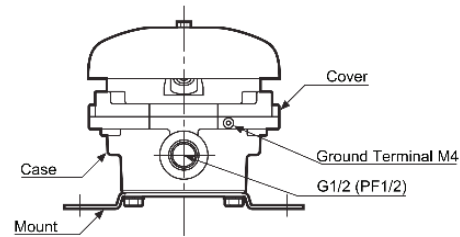
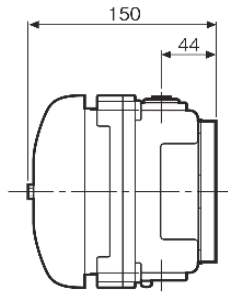
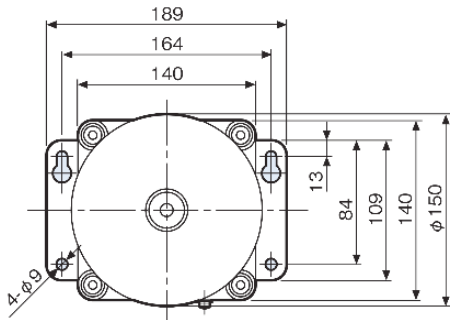

### Specification

Type	Fire Alarm Bell
Model	EMB-6
Structure Explosion Proof Grade	Explosion Proof Type Exd II BT4 (d2G4)
Alarm Current	15mA @24Vdc
Sound Level	Over 92dB (At Front 1m)
Operating Temp. Range	-20°C to 60°C
Material Gong Cover, Case	Aluminum Alloy Aluminum Alloy
Color Gong Cover, Case	Munsell 7.1R3.6/12.8 Munsell 5Y7/1
Weight	Approx. 3.0kg
Country of Origin	Japan
Approval	JFEII

#### HOCHIKI ASIA PACIFIC PTE. LTD.

82 Ubi Ave 4 #06-02  
Edward Boustead Centre, Singapore 408832  
TEL: 65-6841-9728 | FAX: 65-6841-9781  
URL : [www.hochikiasiapacific.com](http://www.hochikiasiapacific.com)

04/2020

#### HEAD OFFICE

10-43 Kamiosaki 2-Chome.  
Shinagawa-Ku, Tokyo 141-8660 Japan  
TEL: 81-(3)-3444-4116 | FAX: 81-(3)-3444-4167  
URL : [www.hochiki.co.jp](http://www.hochiki.co.jp)

Specifications subject to change without notice